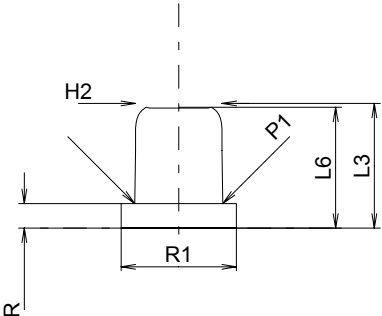
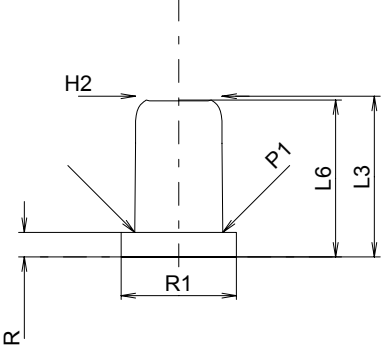
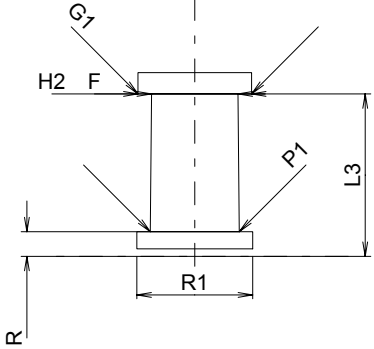
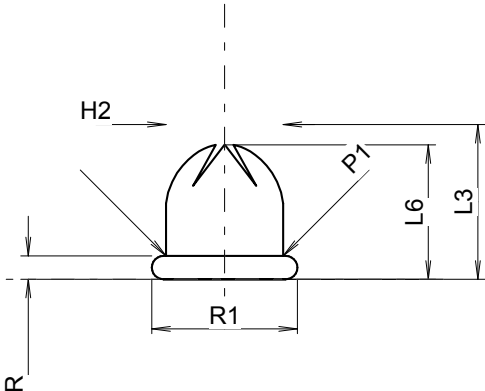

C.I.P.	4 mm Randz. court Blanc	TAB.	VIII
		Datum	92-03-12
		Revision	92-06-10
Ursprungsland: DE			
	PATRONE MAXI	PATRONENLAGER MINI	
	<p>Längen</p> <p>L1 =</p> <p>L2 =</p> <p>L3 ¹⁾ = 6.60</p> <p>L4 =</p> <p>L5 =</p> <p>L6 ¹⁾ = 6.40</p> <p>Hülsenboden</p> <p>R = 1.30</p> <p>R1 = 6.10</p> <p>R3 =</p> <p>E =</p> <p>E1 =</p> <p>e min =</p> <p>δ =</p> <p>f =</p> <p>β =</p> <p>Pulverkammer</p> <p>P1 = 4.65</p> <p>P2 =</p> <p>Schulterkonus</p> <p>α =</p> <p>S =</p> <p>r1 min =</p> <p>r2 =</p> <p>Hülshals</p> <p>H1 =</p> <p>H2 ¹⁾ = 4.58</p> <p>Geschoß</p> <p>G1 =</p> <p>G2 =</p> <p>F =</p> <p>L3+G =</p> <p>Drücke (Energien)</p> <p>Energie</p> <p>E_{max} = 30.0 Joule</p> <p>E_K = 32.1 Joule</p> <p>E_E = 34.5 Joule</p> <p>Verschiedene Daten</p> <p>Fe =</p> <p>delta L =</p>	<p>Längen</p> <p>L1 =</p> <p>L2 =</p> <p>L3 ¹⁾ = 6.70</p> <p>Stoßboden</p> <p>R ¹⁾ = 1.30</p> <p>R1 = 6.13</p> <p>R2 =</p> <p>R3 =</p> <p>r =</p> <p>Pulverkammer</p> <p>E =</p> <p>P1 ¹⁾ = 4.70</p> <p>P2 =</p> <p>Schulterkonus</p> <p>α =</p> <p>S =</p> <p>r1 max =</p> <p>r2 =</p> <p>Hülshals</p> <p>H1 =</p> <p>H2 ¹⁾ = 4.58</p> <p>Übergang</p> <p>G1 ^{2)*} = 6.00</p> <p>G =</p> <p>α1 = 180°</p> <p>h =</p> <p>s =</p> <p>i =</p> <p>w =</p> <p>Lauf</p> <p>F ^{2)*} = 6.00</p> <p>Z = 6.00</p> <p>Züge</p> <p>b =</p> <p>N =</p> <p>u =</p> <p>Q ²⁾ = 28.27 mm²</p>	
<p>Maßstab 2.5:1</p> <p>Maße in << mm >></p> <p>Maße und Toleranzen für Messläufe siehe Anhang CR 5.</p>	<p>Bemerkungen: 1) Kontrolle aus Sicherheitsgründen 2) Gilt nur für Messläufe * Grundmaße</p>		

C.I.P.	4 mm Randz. long Blanc	TAB.	VIII
		Datum	92-03-12
		Revision	92-06-10
Ursprungsland: DE			
	PATRONE MAXI	PATRONENLAGER MINI	
	<p>Längen</p> <p>L1 =</p> <p>L2 =</p> <p>L3 ¹⁾ = 8.50</p> <p>L4 =</p> <p>L5 =</p> <p>L6 ¹⁾ = 8.30</p> <p>Hülsenboden</p> <p>R = 1.30</p> <p>R1 = 6.10</p> <p>R3 =</p> <p>E =</p> <p>E1 =</p> <p>e min =</p> <p>δ =</p> <p>f =</p> <p>β =</p> <p>Pulverkammer</p> <p>P1 = 4.65</p> <p>P2 =</p> <p>Schulterkonus</p> <p>α =</p> <p>S =</p> <p>r1 min =</p> <p>r2 =</p> <p>Hülshals</p> <p>H1 =</p> <p>H2 ¹⁾ = 4.58</p> <p>Geschoß</p> <p>G1 =</p> <p>G2 =</p> <p>F =</p> <p>L3+G =</p> <p>Drücke (Energien)</p> <p>Energie</p> <p>E_{max} = 30.0 Joule</p> <p>E_K = 32.1 Joule</p> <p>E_E = 34.5 Joule</p> <p>Verschiedene Daten</p> <p>Fe =</p> <p>delta L =</p>	<p>Längen</p> <p>L1 =</p> <p>L2 =</p> <p>L3 ¹⁾ = 8.60</p> <p>Stoßboden</p> <p>R ¹⁾ = 1.30</p> <p>R1 = 6.13</p> <p>R2 =</p> <p>R3 =</p> <p>r =</p> <p>Pulverkammer</p> <p>E =</p> <p>P1 ¹⁾ = 4.70</p> <p>P2 =</p> <p>Schulterkonus</p> <p>α =</p> <p>S =</p> <p>r1 max =</p> <p>r2 =</p> <p>Hülshals</p> <p>H1 =</p> <p>H2 ¹⁾ = 4.58</p> <p>Übergang</p> <p>G1 ^{2)*} = 6.00</p> <p>G =</p> <p>α1 = 180°</p> <p>h =</p> <p>s =</p> <p>i =</p> <p>w =</p> <p>Lauf</p> <p>F ^{2)*} = 6.00</p> <p>Z = 6.00</p> <p>Züge</p> <p>b =</p> <p>N =</p> <p>u =</p> <p>Q ²⁾ = 28.27 mm²</p>	
			
Maßstab 2.5:1			
Maße in << mm >> Maße und Toleranzen für Messläufe siehe Anhang CR 5.	Bemerkungen: 1) Kontrolle aus Sicherheitsgründen 2) Gilt nur für Messläufe * Grundmaße		

C.I.P.	6mm Flobert Blanc	TAB.	VIII
		Datum	91-08-02
		Revision	08-04-15
Ursprungsland: FR			
	PATRONE MAXI	PATRONENLAGER MINI	
	<p>Längen</p> <p>L1 =</p> <p>L2 =</p> <p>L3 ¹⁾ = 7.60</p> <p>L4 =</p> <p>L5 =</p> <p>L6 ¹⁾ = 6.60</p> <p>Hülsenboden</p> <p>R = 1.15</p> <p>R1 = 7.15</p> <p>R3 =</p> <p>E =</p> <p>E1 =</p> <p>e min =</p> <p>δ =</p> <p>f =</p> <p>β =</p> <p>Pulverkammer</p> <p>P1 ¹⁾ = 5.75</p> <p>P2 =</p> <p>Schulterkonus</p> <p>α =</p> <p>S =</p> <p>r1 min =</p> <p>r2 =</p> <p>Hülsenhals</p> <p>H1 =</p> <p>H2 ¹⁾ = 5.75</p> <p>Geschoss</p> <p>G1 =</p> <p>G2 =</p> <p>F =</p> <p>L3+G =</p> <p>Drücke (Energien)</p> <p>Energie</p> <p>E_{max} = 42.0 Joule</p> <p>E_K = 44.9 Joule</p> <p>E_E = 46.2 Joule</p> <p>Verschiedene Daten</p> <p>Fe =</p> <p>delta L =</p>	<p>Längen</p> <p>L1 =</p> <p>L2 =</p> <p>L3 ¹⁾ = 7.80</p> <p>Stoßboden</p> <p>R ¹⁾ = 1.15</p> <p>R1 = 7.30</p> <p>R2 =</p> <p>R3 =</p> <p>r =</p> <p>Pulverkammer</p> <p>E =</p> <p>P1 ¹⁾ = 5.76</p> <p>P2 =</p> <p>Schulterkonus</p> <p>α =</p> <p>S =</p> <p>r1 max =</p> <p>r2 =</p> <p>Hülsenhals</p> <p>H1 =</p> <p>H2 ¹⁾ = 5.76</p> <p>Geschossübergang</p> <p>G1 ²⁾* = 6.00</p> <p>G =</p> <p>α1 = 180°</p> <p>h =</p> <p>s =</p> <p>i =</p> <p>w =</p> <p>Lauf</p> <p>F ²⁾* = 6.00</p> <p>Z = 6.00</p> <p>Züge</p> <p>b =</p> <p>N =</p> <p>u =</p> <p>Q ²⁾ = 28.27 mm²</p>	
<p>Maßstab 2.69:1</p> <p>Maße in << mm >></p> <p>Maße und Toleranzen für Messläufe siehe Anhang CR 5.</p>	<p>Bemerkungen: 1) Kontrolle aus Sicherheitsgründen 2) Toleranz für Messlauf * Grundmaße</p>		

C.I.P.	8 mm Blanc	TAB.	VIII
		Datum	91-07-29
		Revision	08-09-23
		Ursprungsland: D	
		PATRONE MAXI	
		PATRONENLAGER MINI	
		Längen	
<p>Maßstab 1.88:1</p> <p>Maße in << mm >> Maße und Toleranzen für Messläufe siehe Anhang CR 5.</p>		<p>Längen</p> <p>L1 * = 20.00</p> <p>L2 * = 20.00</p> <p>L3 1) = 20.30</p> <p>L4 =</p> <p>L5 =</p> <p>L6 1) = 20.60</p>	
		<p>Hülsenboden</p> <p>R = 1.27</p> <p>R1 = 8.00</p> <p>R3 =</p> <p>E = 3.33</p> <p>E1 = 6.55</p> <p>e min = 0.80</p> <p>delta = 30°</p> <p>f = 0.20</p> <p>beta = 45°</p>	
<p>Mech. elektr. Wandler</p> <p>Pmax = 450 bar</p> <p>PK = 518 bar</p> <p>PE = 585 bar</p> <p>M = 7.00</p>		<p>Pulverkammer</p> <p>P1 = 8.00</p> <p>P2 =</p>	
		<p>Schulterkonus</p> <p>alpha =</p> <p>S =</p> <p>r1 min =</p> <p>r2 =</p>	
<p>Verschiedene Daten</p> <p>Fe =</p> <p>delta L =</p>		<p>Hülsenboden</p> <p>R =</p> <p>R1 =</p> <p>R2 =</p> <p>R3 =</p> <p>r =</p>	
		<p>Pulverkammer</p> <p>E =</p> <p>P1 1) = 8.02 +0.25</p> <p>P2 =</p>	
<p>Bemerkungen:</p> <p>1) Kontrolle aus Sicherheitsgründen</p> <p>2) Toleranz für Messlauf</p> <p>* Grundmaße</p>		<p>Schulterkonus</p> <p>alpha =</p> <p>S =</p> <p>r1 max =</p> <p>r2 =</p>	
		<p>Hülsenhals</p> <p>H1 =</p> <p>H2 1) = 8.00</p>	
<p>Züge</p> <p>b =</p> <p>N =</p> <p>u =</p> <p>Q 2) = 14.52 mm²</p>		<p>Geschoss</p> <p>G1 =</p> <p>G2 =</p> <p>F =</p> <p>L1+G =</p>	
		<p>Hülsenhals</p> <p>H1 =</p> <p>H2 1) = 8.02</p>	
<p>Lauf</p> <p>F 2)* = 4.30</p> <p>Z = 4.30</p>		<p>Geschossübergang</p> <p>G1 2)* = 6.00</p> <p>G 2)* = 10.85</p> <p>alpha1 = 90°</p> <p>h = 1.01</p> <p>s * = 10.00</p> <p>i = 45°</p> <p>w =</p>	
		<p>Drücke (Energien)</p>	

C.I.P.	9 mm PA Blanc	TAB.	VIII
		Datum	91-07-30
		Revision	94-03-01
Ursprungsland: DE			
	PATRONE MAXI	PATRONENLAGER MINI	
	<p>Längen</p> <p>L1 =</p> <p>L2* = 22.00</p> <p>L3¹⁾ = 22.50</p> <p>L4 =</p> <p>L5 =</p> <p>L6¹⁾ = 22.70</p> <p>Hülsenboden</p> <p>R = 1.25</p> <p>R1 = 9.50</p> <p>R3 =</p> <p>E = 2.97</p> <p>E1 = 8.30</p> <p>e min = 1.00</p> <p>δ = 40°</p> <p>f = 0.40</p> <p>β = 45°</p> <p>Pulverkammer</p> <p>P1 = 9.50</p> <p>P2 =</p> <p>Schulterkonus</p> <p>α =</p> <p>S =</p> <p>r1 min =</p> <p>r2 =</p> <p>Hülsenhals</p> <p>H1 =</p> <p>H2¹⁾ = 9.50</p> <p>Geschoß</p> <p>G1 =</p> <p>G2 =</p> <p>F =</p> <p>L3+G =</p> <p>Drücke (Energien)</p> <p>Mech. elektr. Wandler</p> <p>Pmax = 400 bar</p> <p>PK = 460 bar</p> <p>PE = 520 bar</p> <p>M = 8.50</p> <p>Verschiedene Daten</p> <p>Fe =</p> <p>delta L =</p>	<p>Längen</p> <p>L1 =</p> <p>L2 =</p> <p>L3¹⁾ = 20.70</p> <p>Stoßboden</p> <p>R =</p> <p>R1 =</p> <p>R2 =</p> <p>R3 =</p> <p>r =</p> <p>Pulverkammer</p> <p>E =</p> <p>P1¹⁾ = 9.55</p> <p>P2 =</p> <p>Schulterkonus</p> <p>α =</p> <p>S =</p> <p>r1 max =</p> <p>r2 =</p> <p>Hülsenhals</p> <p>H1 =</p> <p>H2¹⁾ = 9.55</p> <p>Übergang</p> <p>G1^{2)*} = 8.00</p> <p>G^{2)*} = 4.70</p> <p>α1 = 90°</p> <p>h = 0.77</p> <p>s* = 3.50</p> <p>i = 45°</p> <p>w =</p> <p>Lauf</p> <p>F^{2)*} = 5.60</p> <p>Z = 5.60</p> <p>Züge</p> <p>b =</p> <p>N =</p> <p>u =</p> <p>Q²⁾ = 24.63 mm²</p>	
Maßstab 1.5:1			
Maße in << mm >> Maße und Toleranzen für Messläufe siehe Anhang CR 5.	Bemerkungen: 1) Kontrolle aus Sicherheitsgründen 2) Gilt nur für Messläufe * Grundmaße		

C.I.P.	10TK	TAB.	VIII
		Datum	16-05-18
		Revision	
		Ursprungsland: RU	
		PATRONE MAXI	
		PATRONE MINI	
		Längen	
		Längen L1 = L2 = L3 ¹⁾ = 22.10 L4 = L5 = L6 ¹⁾ = 21.50	
		Hülsenboden R = 1.50 R1 = 10.00 R3 = E = 3.20 E1 = 8.60 e min = 1.00 delta = 45° f = 0.50 beta = 45°	
		Stoßboden R = R1 = 10.10 R2 = R3 = r =	
		Pulverkammer P1 = 10.00 P2 =	
		Pulverkammer E = P1 ¹⁾ = 10.10 P2 * =	
		Schulterkonus alpha = S = r1 min = r2 =	
		Schulterkonus alpha ¹⁾ = S = r1 max = r2 =	
		Hülsenhals H1 = H2 ¹⁾ = 9.76	
		Hülsenhals H1 = H2 ¹⁾ = 9.94	
		Geschoss G1 = G2 = F = L3+G ¹⁾ =	
		Geschossübergang G1 ^{2)*} = 5.50 G ²⁾ = alpha 1 = 60° h * = 3.85 s = i = w =	
		Drücke (Energien) Mech. elektr. Wandler Pmax = 800 bar PK = 920 bar PE = 1040 bar M = 8.50	
		Lauf F ^{2)*} = 5.50 Z = 5.50	
		Züge b = N = u = Q = 23.76 mm ²	
		Verschiedene Daten Fe ¹⁾ = delta L =	
		Bemerkungen: 1) Kontrolle aus Sicherheitsgründen 2) Toleranz für Messlauf * Grundmaße	
Maßstab 1.69:1 Maße in << mm >> Maße und Toleranzen für Messläufe siehe Anhang CR 1.			

C.I.P.	22 Long Blanc Ursprungsland: IT	TAB.	VIII
		Datum	91-08-02
		Revision	94-03-01
	<p>PATRONE MAXI</p> <p>Längen</p> <p>L1 =</p> <p>L2 =</p> <p>L3 ¹⁾ = 15.57</p> <p>L4 =</p> <p>L5 =</p> <p>L6 ¹⁾ = 15.00</p> <p>Hülsenboden</p> <p>R = 1.09</p> <p>R1 = 7.06</p> <p>R3 =</p> <p>E =</p> <p>E1 =</p> <p>e min =</p> <p>δ =</p> <p>f =</p> <p>β =</p> <p>Pulverkammer</p> <p>P1 = 5.74</p> <p>P2 =</p> <p>Schulterkonus</p> <p>α =</p> <p>S =</p> <p>r1 min =</p> <p>r2 =</p> <p>Hülsenhals</p> <p>H1 =</p> <p>H2 ¹⁾ = 5.72</p> <p>Geschoß</p> <p>G1 =</p> <p>G2 =</p> <p>F =</p> <p>L3+G =</p> <p>Drücke (Energien)</p> <p>Mech. elektr. Wandler</p> <p>Pmax = 500 bar</p> <p>PK = 575 bar</p> <p>PE = 650 bar</p> <p>M = 7.00</p> <p>Verschiedene Daten</p> <p>Fe =</p> <p>delta L =</p>	<p>PATRONENLAGER MINI</p> <p>Längen</p> <p>L1 =</p> <p>L2 =</p> <p>L3 ¹⁾ = 15.00</p> <p>Stoßboden</p> <p>R ¹⁾ = 1.09</p> <p>R1 = 7.32</p> <p>R2 =</p> <p>R3 =</p> <p>r =</p> <p>Pulverkammer</p> <p>E =</p> <p>P1 ¹⁾ = 5.76</p> <p>P2 =</p> <p>Schulterkonus</p> <p>α =</p> <p>S =</p> <p>r1 max =</p> <p>r2 =</p> <p>Hülsenhals</p> <p>H1 =</p> <p>H2 ¹⁾ = 5.74</p> <p>Übergang</p> <p>G1 ^{2)*} = 5.00</p> <p>G ^{2)*} = 5.35</p> <p>α1 = 90°</p> <p>h = 0.37</p> <p>s* = 5.00</p> <p>i = 45°</p> <p>w =</p> <p>Lauf</p> <p>F ^{2)*} = 4.30</p> <p>Z = 4.30</p> <p>Züge</p> <p>b =</p> <p>N =</p> <p>u =</p> <p>Q ²⁾ = 14.52 mm²</p>	
<p>Maßstab 2:1</p> <p>Maße in << mm >> Maße und Toleranzen für Messläufe siehe Anhang CR 5.</p>	<p>Bemerkungen: 1) Kontrolle aus Sicherheitsgründen 2) Gilt nur für Messläufe * Grundmaße</p>		

C.I.P.	315 Blanc Ursprungsland: DE	TAB. VIII
		Datum 91-07-29
		Revision 94-03-01
	PATRONE MAXI	PATRONENLAGER MINI
	<p>Längen</p> <p>L1 =</p> <p>L2* = 17.00</p> <p>L3¹⁾ = 17.65</p> <p>L4 =</p> <p>L5 =</p> <p>L6¹⁾ = 17.70</p> <p>Hülsenboden</p> <p>R = 1.27</p> <p>R1 = 8.00</p> <p>R3 =</p> <p>E = 3.33</p> <p>E1 = 6.55</p> <p>e min = 0.80</p> <p>δ = 30°</p> <p>f = 0.20</p> <p>β = 45°</p> <p>Pulverkammer</p> <p>P1 = 8.00</p> <p>P2 =</p> <p>Schulterkonus</p> <p>α =</p> <p>S =</p> <p>r1 min =</p> <p>r2 =</p> <p>Hülsenhals</p> <p>H1 =</p> <p>H2¹⁾ = 8.00</p> <p>Geschoß</p> <p>G1 =</p> <p>G2 =</p> <p>F =</p> <p>L3+G =</p> <p>Drücke (Energien)</p> <p>Mech. elektr. Wandler</p> <p>Pmax = 450 bar</p> <p>PK = 518 bar</p> <p>PE = 585 bar</p> <p>M = 7.00</p> <p>Verschiedene Daten</p> <p>Fe =</p> <p>delta L =</p>	<p>Längen</p> <p>L1 =</p> <p>L2 =</p> <p>L3¹⁾ = 16.20</p> <p>Stoßboden</p> <p>R =</p> <p>R1 =</p> <p>R2 =</p> <p>R3 =</p> <p>r =</p> <p>Pulverkammer</p> <p>E =</p> <p>P1¹⁾ = 8.02</p> <p>P2 =</p> <p>Schulterkonus</p> <p>α =</p> <p>S =</p> <p>r1 max =</p> <p>r2 =</p> <p>Hülsenhals</p> <p>H1 =</p> <p>H2¹⁾ = 8.02</p> <p>Übergang</p> <p>G1^{2)*} = 6.00</p> <p>G^{2)*} = 10.85</p> <p>α1 = 90°</p> <p>h = 1.01</p> <p>s* = 10.00</p> <p>i = 45°</p> <p>w =</p> <p>Lauf</p> <p>F^{2)*} = 4.30</p> <p>Z = 4.30</p> <p>Züge</p> <p>b =</p> <p>N =</p> <p>u =</p> <p>Q²⁾ = 14.52 mm²</p>
<p>Maßstab 1.5:1</p> <p style="text-align: center;">Maße in << mm >> Maße und Toleranzen für Messläufe siehe Anhang CR 5.</p>	<p>Bemerkungen: 1) Kontrolle aus Sicherheitsgründen 2) Gilt nur für Messläufe * Grundmaße</p>	

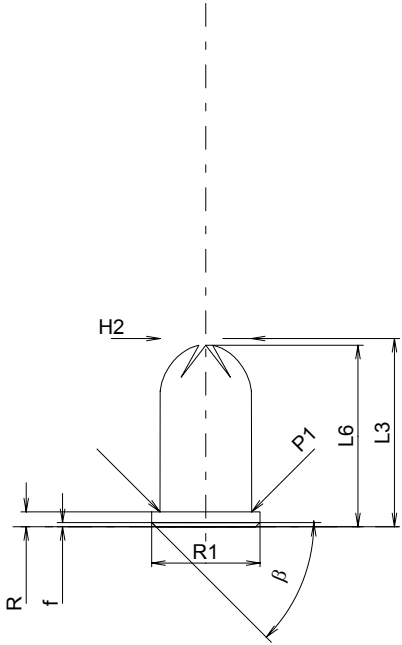
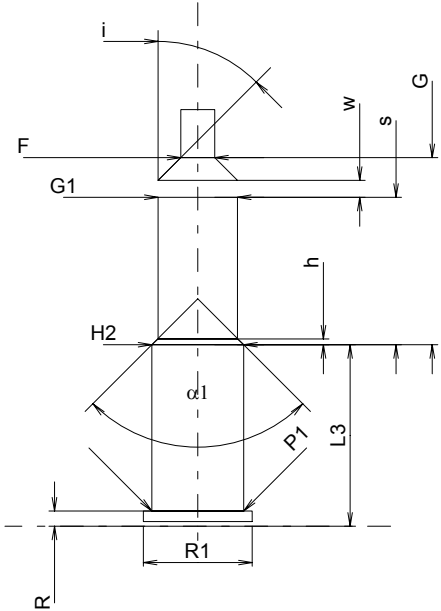
C.I.P.	320 Court Blanc Ursprungsland: DE	TAB.	VIII
		Datum	91-07-29
		Revision	94-03-01
	<p align="center">PATRONE MAXI</p> <p>Längen</p> <p>L1 = L2 = L3 ¹⁾ = 16.60 L4 = L5 = L6 ¹⁾ = 16.00</p> <p>Hülsenboden</p> <p>R = 1.32 R1 = 9.55 R3 = E = E1 = e min = delta = f = 0.38 beta = 45°</p> <p>Pulverkammer</p> <p>P1 = 8.09 P2 =</p> <p>Schulterkonus</p> <p>alpha = S = r1 min = r2 =</p> <p>Hülsenhals</p> <p>H1 = H2 ¹⁾ = 8.05</p> <p>Geschoß</p> <p>G1 = G2 = F = L3+G =</p> <p>Drücke (Energien) Mech. elektr. Wandler</p> <p>Pmax = 250 bar PK = 288 bar PE = 325 bar M = 7.50</p> <p>Verschiedene Daten</p> <p>Fe = delta L =</p>	<p align="center">PATRONENLAGER MINI</p> <p>Längen</p> <p>L1 = L2 = L3 ¹⁾ = 16.00</p> <p>Stoßboden</p> <p>R ¹⁾ = 1.35 R1 = 9.60 R2 = R3 = r =</p> <p>Pulverkammer</p> <p>E = P1 ¹⁾ = 8.10 P2 =</p> <p>Schulterkonus</p> <p>alpha = S = r1 max = r2 =</p> <p>Hülsenhals</p> <p>H1 = H2 ¹⁾ = 8.10</p> <p>Übergang</p> <p>G1 ^{2)*} = 7.00 G ^{2)*} = 16.50 alpha1 = 90° h = 0.50 s* = 13.00 i = 45° w = 1.50</p> <p>Lauf</p> <p>F ^{2)*} = 3.00 Z = 3.00</p> <p>Züge</p> <p>b = N = u = Q ²⁾ = 7.07 mm²</p>	
		<p>Maßstab 1.5:1</p> <p align="center">Maße in << mm >> Maße und Toleranzen für Messläufe siehe Anhang CR 5.</p>	<p>Bemerkungen: 1) Kontrolle aus Sicherheitsgründen 2) Gilt nur für Messläufe * Grundmaße</p>

C.I.P.	35 Blanc Ursprungsland: DE	TAB.	VIII
		Datum	92-03-12
		Revision	94-06-01
	<p align="center">PATRONE MAXI</p> <p>Längen</p> <p>L1 =</p> <p>L2* = 25.30</p> <p>L3¹⁾ = 25.80</p> <p>L4 =</p> <p>L5 =</p> <p>L6¹⁾ = 26.00</p> <p>Hülsenboden</p> <p>R = 1.30</p> <p>R1 = 9.50</p> <p>R3 =</p> <p>E = 3.20</p> <p>E1 = 8.20</p> <p>e min = 1.00</p> <p>δ = 40°</p> <p>f = 0.40</p> <p>β = 45°</p> <p>Pulverkammer</p> <p>P1 = 9.50</p> <p>P2 =</p> <p>Schulterkonus</p> <p>α =</p> <p>S =</p> <p>r1 min =</p> <p>r2 =</p> <p>Hülsenhals</p> <p>H1 =</p> <p>H2¹⁾ = 9.50</p> <p>Geschoß</p> <p>G1 =</p> <p>G2 =</p> <p>F =</p> <p>L3+G =</p> <p>Drücke (Energien)</p> <p>Mech. elektr. Wandler</p> <p>Pmax = 450 bar</p> <p>PK = 518 bar</p> <p>PE = 585 bar</p> <p>M = 8.50</p> <p>Verschiedene Daten</p> <p>Fe =</p> <p>delta L =</p>	<p align="center">PATRONENLAGER MINI</p> <p>Längen</p> <p>L1 =</p> <p>L2 =</p> <p>L3¹⁾ = 24.00</p> <p>Stoßboden</p> <p>R =</p> <p>R1 =</p> <p>R2 =</p> <p>R3 =</p> <p>r =</p> <p>Pulverkammer</p> <p>E =</p> <p>P1¹⁾ = 9.55 +0.20</p> <p>P2 =</p> <p>Schulterkonus</p> <p>α =</p> <p>S =</p> <p>r1 max =</p> <p>r2 =</p> <p>Hülsenhals</p> <p>H1 =</p> <p>H2¹⁾ = 9.55</p> <p>Übergang</p> <p>G1^{2)*} = 6.00</p> <p>G^{2)*} = 11.85</p> <p>α1 = 90°</p> <p>h = 1.77</p> <p>s* = 11.00</p> <p>i = 45°</p> <p>w =</p> <p>Lauf</p> <p>F^{2)*} = 4.30</p> <p>Z = 4.30</p> <p>Züge</p> <p>b =</p> <p>N =</p> <p>u =</p> <p>Q²⁾ = 14.52 mm²</p>	
	<p>Maßstab 1.5:1</p> <p align="center">Maße in << mm >> Maße und Toleranzen für Messläufe siehe Anhang CR 5.</p>	<p>Bemerkungen: 1) Kontrolle aus Sicherheitsgründen 2) Gilt nur für Messläufe * Grundmaße</p>	

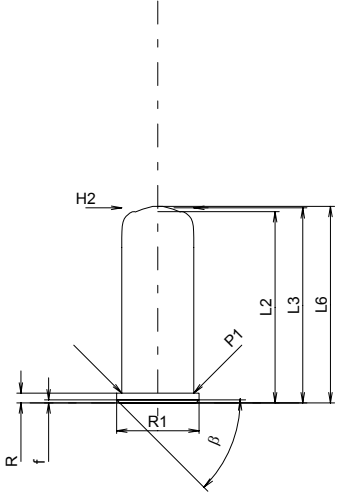
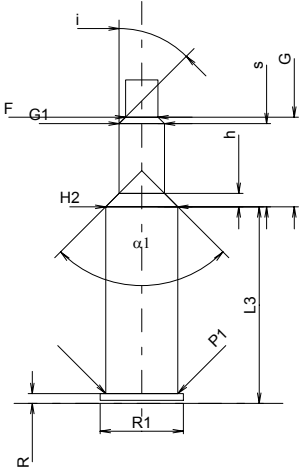
C.I.P.	35 R Blanc		TAB.	VIII
	Ursprungsland: DE		Datum	92-03-12
			Revision	94-03-01
	PATRONE MAXI Längen L1 = L2 * = 25.30 L3 ¹⁾ = 25.80 L4 = L5 = L6 ¹⁾ = 26.00 Hülsenboden R = 1.30 R1 = 10.90 R3 = E = E1 = e min = delta = f = 0.40 beta = 45° Pulverkammer P1 = 9.50 P2 = Schulterkonus alpha = S = r1 min = r2 = Hülshals H1 = H2 ¹⁾ = 9.50 Geschoß G1 = G2 = F = L3+G = Drücke (Energien) Mech. elektr. Wandler Pmax = 450 bar PK = 518 bar PE = 585 bar M = 8.50 Verschiedene Daten Fe = delta L =	PATRONENLAGER MINI Längen L1 = L2 = L3 ¹⁾ = 26.00 Stoßboden R ¹⁾ = 1.30 +0.10 R1 = 11.00 R2 = R3 = r = Pulverkammer E = P1 ¹⁾ = 9.55 P2 = Schulterkonus alpha = S = r1 max = r2 = Hülshals H1 = H2 ¹⁾ = 9.55 Übergang G1 ^{2)*} = 6.00 G ^{2)*} = 11.85 alpha1 = 90° h = 1.77 s * = 11.00 i = 45° w = Lauf F ^{2)*} = 4.30 Z = 4.30 Züge b = N = u = Q ²⁾ = 14.52 mm ²		
				
Maßstab 1:1				
Maße in << mm >> Maße und Toleranzen für Messläufe siehe Anhang CR 5.	Bemerkungen: 1) Kontrolle aus Sicherheitsgründen 2) Gilt nur für Messläufe * Grundmaße			

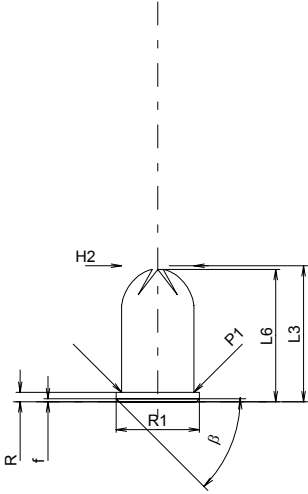
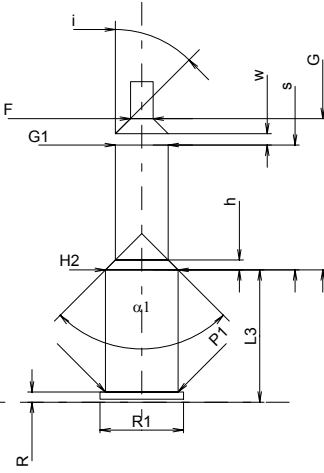
C.I.P.	380 R Blanc / 9 mm R Blanc	TAB.	VIII
		Datum	91-07-30
		Revision	95-05-10
Ursprungsland: IT/DE			
	PATRONE MAXI	PATRONENLAGER MINI	
	<p>Längen</p> <p>L1 =</p> <p>L2 =</p> <p>L3 ¹⁾ = 18.00</p> <p>L4 =</p> <p>L5 =</p> <p>L6 ¹⁾ = 17.50</p> <p>Hülsenboden</p> <p>R = 1.25</p> <p>R1 = 11.00</p> <p>R3 =</p> <p>E =</p> <p>E1 =</p> <p>e min =</p> <p>δ =</p> <p>f = 0.40</p> <p>β = 45°</p> <p>Pulverkammer</p> <p>P1 = 9.58</p> <p>P2 =</p> <p>Schulterkonus</p> <p>α =</p> <p>S =</p> <p>r1 min =</p> <p>r2 =</p> <p>Hülsenhals</p> <p>H1 =</p> <p>H2 ¹⁾ = 9.57</p> <p>Geschoß</p> <p>G1 =</p> <p>G2 =</p> <p>F =</p> <p>L3+G =</p> <p>Drücke (Energien)</p> <p>Mech. elektr. Wandler</p> <p>Pmax = 250 bar</p> <p>PK = 288 bar</p> <p>PE = 325 bar</p> <p>M = 7.50</p> <p>Verschiedene Daten</p> <p>Fe =</p> <p>delta L =</p>	<p>Längen</p> <p>L1 =</p> <p>L2 =</p> <p>L3 ¹⁾ = 17.50</p> <p>Stoßboden</p> <p>R ¹⁾ = 1.35 +0.10</p> <p>R1 = 11.05</p> <p>R2 =</p> <p>R3 =</p> <p>r =</p> <p>Pulverkammer</p> <p>E =</p> <p>P1 ¹⁾ = 9.60</p> <p>P2 =</p> <p>Schulterkonus</p> <p>α =</p> <p>S =</p> <p>r1 max =</p> <p>r2 =</p> <p>Hülsenhals</p> <p>H1 =</p> <p>H2 ¹⁾ = 9.60</p> <p>Übergang</p> <p>G1 ^{2)*} = 7.00</p> <p>G ^{2)*} = 20.00</p> <p>α1 = 90°</p> <p>h = 1.30</p> <p>s * = 16.50</p> <p>i = 45°</p> <p>w = 1.50</p> <p>Lauf</p> <p>F ^{2)*} = 3.00</p> <p>Z = 3.00</p> <p>Züge</p> <p>b =</p> <p>N =</p> <p>u =</p> <p>Q ²⁾ = 7.07 mm²</p>	
			
Maßstab 1:1			
<p>Maße in << mm >></p> <p>Maße und Toleranzen für Messläufe siehe Anhang CR 5.</p>		<p>Bemerkungen: 1) Kontrolle aus Sicherheitsgründen 2) Gilt nur für Messläufe * Grundmaße</p>	

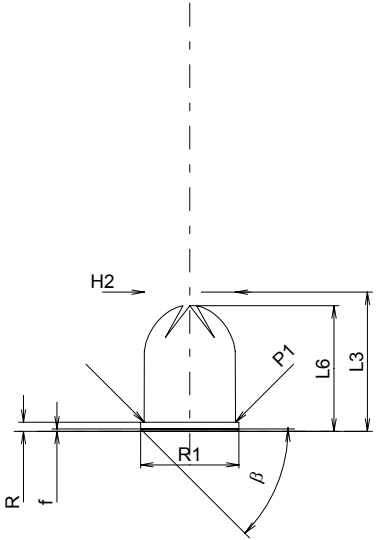
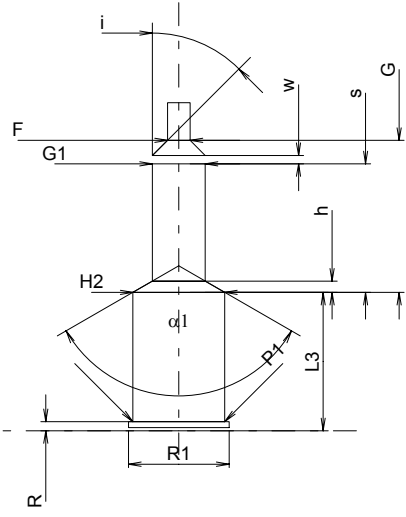
C.I.P.	45 K Blanc Ursprungsland: DE	TAB.	VIII
		Datum	91-08-01
		Revision	94-03-01
	PATRONE MAXI	PATRONENLAGER MINI	
	<p>Längen</p> <p>L1 =</p> <p>L2 =</p> <p>L3 ¹⁾ = 18.40</p> <p>L4 =</p> <p>L5 =</p> <p>L6 ¹⁾ = 16.60</p> <p>Hülsenboden</p> <p>R = 1.20</p> <p>R1 = 13.00</p> <p>R3 =</p> <p>E =</p> <p>E1 =</p> <p>e min =</p> <p>δ =</p> <p>f = 0.30</p> <p>β = 45°</p> <p>Pulverkammer</p> <p>P1 = 12.10</p> <p>P2 =</p> <p>Schulterkonus</p> <p>α =</p> <p>S =</p> <p>r1 min =</p> <p>r2 =</p> <p>Hülsenhals</p> <p>H1 =</p> <p>H2 ¹⁾ = 12.00</p> <p>Geschoß</p> <p>G1 =</p> <p>G2 =</p> <p>F =</p> <p>L3+G =</p> <p>Drücke (Energien)</p> <p>Mech. elektr. Wandler</p> <p>Pmax = 400 bar</p> <p>PK = 460 bar</p> <p>PE = 520 bar</p> <p>M = 7.50</p> <p>Verschiedene Daten</p> <p>Fe =</p> <p>delta L =</p>	<p>Längen</p> <p>L1 =</p> <p>L2 =</p> <p>L3 ¹⁾ = 18.30</p> <p>Stoßboden</p> <p>R ¹⁾ = 1.20</p> <p>R1 = 13.30</p> <p>R2 =</p> <p>R3 =</p> <p>r =</p> <p>Pulverkammer</p> <p>E =</p> <p>P1 ¹⁾ = 12.15</p> <p>P2 =</p> <p>Schulterkonus</p> <p>α =</p> <p>S =</p> <p>r1 max =</p> <p>r2 =</p> <p>Hülsenhals</p> <p>H1 =</p> <p>H2 ¹⁾ = 12.15</p> <p>Übergang</p> <p>G1 ^{2)*} = 7.00</p> <p>G ^{2)*} = 20.10</p> <p>α1 = 120°</p> <p>h = 1.49</p> <p>s* = 17.00</p> <p>i = 45°</p> <p>w = 1.10</p> <p>Lauf</p> <p>F ^{2)*} = 3.00</p> <p>Z = 3.00</p> <p>Züge</p> <p>b =</p> <p>N =</p> <p>u =</p> <p>Q ²⁾ = 7.07 mm²</p>	
			
Maßstab 1:1			
<p>Maße in << mm >></p> <p>Maße und Toleranzen für Messläufe siehe Anhang CR 5.</p>	<p>Bemerkungen: 1) Kontrolle aus Sicherheitsgründen 2) Gilt nur für Messläufe * Grundmaße</p>		

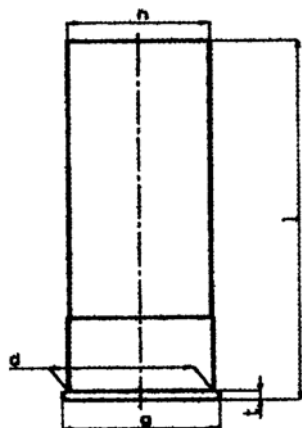
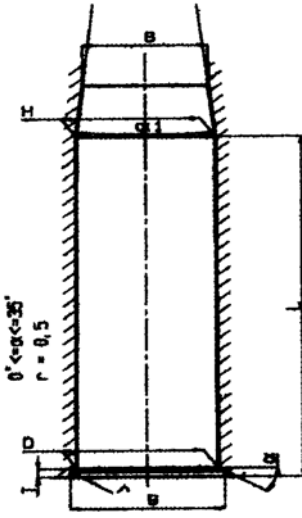
C.I.P.	Kal. 16 Blanc	TAB.	VIII												
		Date	91-12-01												
		Revision	96-06-04												
		<p>PATRONE MAXIMUM</p> <p>Dimens. Wert Toler.</p> <p>d¹⁾ = 18.90 - 0.23 g = 20.65 - 0.33 t¹⁾ = 1.65 - 0.35 h = 18.55 - 0.49 l = 47.00 - 2.50</p>													
		<p>PATRONENLAGER MINIMUM</p> <p>Dimens. Wert Toler.</p> <p>D¹⁾ = 18.95 + 0.10 G = 20.75 + 0.10 T¹⁾ = 1.65 + 0.10 H¹⁾ = 18.60 + 0.10 B¹⁾ = 16.80 + 0.50 α¹⁾ = 90° + 30' L¹⁾ = 45.00 + 2.00</p>		<p>Gasdruck Wandler</p> <table border="1"> <thead> <tr> <th>Pmax</th> <th>PK</th> <th>PE</th> <th>M</th> </tr> </thead> <tbody> <tr> <td></td> <td>bar</td> <td></td> <td></td> </tr> <tr> <td>150</td> <td>173</td> <td>195</td> <td>15</td> </tr> </tbody> </table>		Pmax	PK	PE	M		bar			150	173
Pmax	PK	PE	M												
	bar														
150	173	195	15												
		<p>Verschlussabstand</p> <table border="0"> <tr> <td>Fe = 0.10</td> <td>Messlauf</td> </tr> <tr> <td>Fe¹⁾ = 0.20</td> <td>Mit Basküle</td> </tr> <tr> <td>Fe¹⁾ = 0.35</td> <td>Automat</td> </tr> </table>				Fe = 0.10	Messlauf	Fe ¹⁾ = 0.20	Mit Basküle	Fe ¹⁾ = 0.35	Automat				
Fe = 0.10	Messlauf														
Fe ¹⁾ = 0.20	Mit Basküle														
Fe ¹⁾ = 0.35	Automat														
<p>Maßstab 1:1</p>															
<p>Dimensionen in « mm » Dimensionen und Toleranzen für Messläufe: Siehe Anhang CR 4.</p>		<p>Bemerkung: 1) Kontrolle aus Sicherheitsgründen</p>													

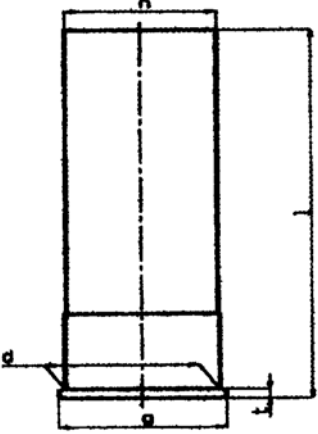
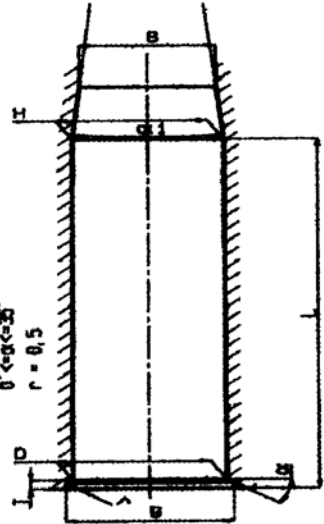
C.I.P.	Kal. 12 Blanc	TAB.	VIII										
		Datum	91-12-01										
		Revision	96-06-04										
		<p>PATRONE MAXIMUM</p> <p>Dimens. Wert Toler.</p> <p>d¹⁾ = 20.60 - 0.28 g = 22.45 - 0.48 t¹⁾ = 1.85 - 0.35 h = 20.20 - 0.47 l = 49.00 - 2.50</p>											
		<p>PATRONENLAGER MINIMUM</p> <p>Dimens. Wert Toler.</p> <p>D¹⁾ = 20.65 + 0.10 G = 22.55 + 0.10 T¹⁾ = 1.85 + 0.10 H¹⁾ = 20.30 + 0.10 B¹⁾ = 18.80 + 0.70 α¹⁾ = 90° + 30' L¹⁾ = 45.00 + 2.00</p>		<p>Gasdruck Wandler</p> <table border="1"> <thead> <tr> <th>Pmax</th> <th>PK</th> <th>PE</th> <th>M</th> </tr> </thead> <tbody> <tr> <td>150</td> <td>173</td> <td>195</td> <td>15</td> </tr> </tbody> </table>		Pmax	PK	PE	M	150	173	195	15
Pmax	PK	PE	M										
150	173	195	15										
		<p>Verschlussabstand</p> <table border="1"> <thead> <tr> <th>Fe</th> <th>Messlauf</th> </tr> </thead> <tbody> <tr> <td>= 0.10</td> <td>Mit Basküle</td> </tr> <tr> <td>Fe¹⁾ = 0.20</td> <td>Automat</td> </tr> <tr> <td>Fe¹⁾ = 0.35</td> <td></td> </tr> </tbody> </table>				Fe	Messlauf	= 0.10	Mit Basküle	Fe ¹⁾ = 0.20	Automat	Fe ¹⁾ = 0.35	
Fe	Messlauf												
= 0.10	Mit Basküle												
Fe ¹⁾ = 0.20	Automat												
Fe ¹⁾ = 0.35													
<p>Maßstab 1:1</p>													
<p>Dimensionen in « mm » Dimensionen und Toleranzen für Messläufe: Siehe Anhang CR 4.</p>		<p>Bemerkung : 1) Kontrolle aus Sicherheitsgründen</p>											

